

Autonics ROTARY ENCODER(INCREMENTAL TYPE) ENA/ENC SERIES INSTRUCTION MANUAL



Thank you for choosing our Autonics product.
Please read the following safety considerations before use.

■ Safety Considerations

- ※Please observe all safety considerations for safe and proper product operation to avoid hazards.
- ※⚠ symbol represents caution due to special circumstances in which hazards may occur.
- Warning** Failure to follow these instructions may result in serious injury or death.
- Caution** Failure to follow these instructions may result in personal injury or product damage.
- Warning**
 - Fail-safe device must be installed when using the unit with machinery that may cause serious injury or substantial economic loss. (e.g. nuclear power control, medical equipment, ships, vehicles, railways, aircraft, combustion apparatus, safety equipment, crime/disaster prevention devices, etc.)
 - Install on a device panel to use.
 - Do not connect, repair, or inspect the unit while connected to a power source.
 - Check 'Connections' before wiring.
 - Do not disassemble or modify the unit.

- Caution**
 - Use the unit within the rated specifications.
 - Do not short the load.
 - Do not use the unit in the place where flammable/explosive/corrosive gas, humidity, direct sunlight, radiant heat, vibration, impact, or salinity may be present.
 - Do not use the unit near the place where there is the equipment which generates strong magnetic force or high frequency noise and strong alkaline, strong acidic exists.

■ Ordering Information

ENA	-	5000	-	2	-	N	-	24
Series	Pulses/Revolution	Output phase	Control output	Power supply				
Side-mounting shaft type (external diameter of shaft: Ø10mm)	See resolution	2: A, B 3: A, B, Z	T: Totem Pole output N: NPN open collector output V: Voltage output	5: 5VDC ±5% 24: 12-24VDC ±5%				
ENC	-	1	-	1	-	N	-	24
Series	Output phase	Min. measuring unit	Control output	Power supply	Cable			
Wheel type	1: A, B	1: 1mm 4: 0.01yd 2: 1cm 5: 0.1yd 3: 1m 6: 1yd	T: Totem Pole output N: NPN open collector output V: Voltage output	5: 5VDC ±5% 24: 12-24VDC ±5%	No mark : Axial cable type C: Axial cable connector type(※)	※Cable length: 250mm		

■ Control Output Diagram

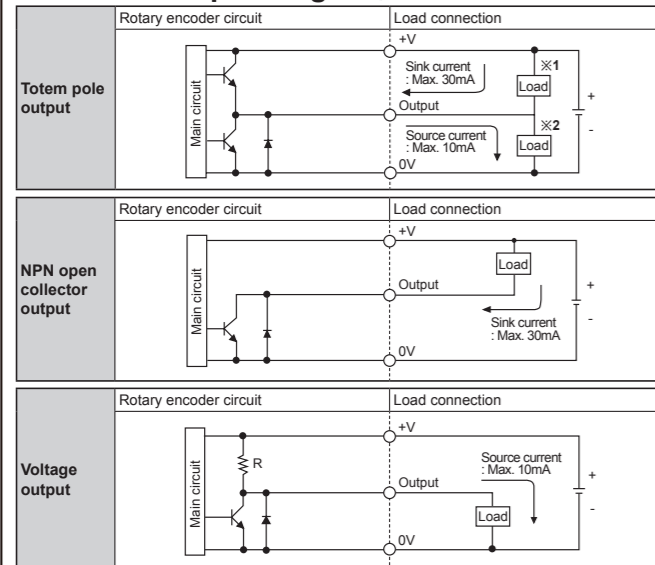

※All output circuits of A, B, Z phase are the same.
 ※Totem pole output type can be used for NPN open collector type(※1) or voltage output type(※2).
 ※The above specifications are subject to change and some models may be discontinued without notice.
 ※Be sure to follow cautions written in the instruction manual, and the technical descriptions (catalog, homepage).

■ Specifications

Item	Side-mounting shaft type of incremental rotary encoder	Wheel type of incremental rotary encoder	
Model	Totem pole output	ENA-□-□-□-□	
	NPN open collector output	ENC-1-□-□-□-□	
	Voltage output	ENC-1-□-□-□-□	
Resolution(PPR) ^{※1}	*1, *2, *5, 10, 12, 15, 20, 23, 25, 30, 35, 40, 45, 50, 60, 75, 100, 120, 125, 150, 192, 200, 240, 250, 256, 300, 360, 400, 500, 512, 600, 800, 1000, 1024, 1200, 1500, 1800, 2000, 2048, 2500, 3000, 3600, 5000	1mm/Pulse, 1cm/Pulse, 1m/Pulse, 0.01yd/Pulse, 0.1yd/Pulse, 1yd/Pulse	
Output phase	ENA-□-□-□-□ : A, B phase ENA-□-□-□-□ : A, B, Z phase	A, B phase	
Electrical specification	Phase difference of output	Output between A and B phase: $\frac{T}{4} \pm \frac{T}{8}$ (T = 1 cycle of A phase)	
	Control output	Totem pole output	• [Low] - Load current: Max. 30mA, Residual voltage: Max. 0.4VDC= • [High] - Load current: Max. 10mA, Output voltage(Power voltage 5VDC=): Min. (Power voltage-2.0)VDC= Output voltage(Power voltage 12-24VDC=): Min. (Power voltage-3.0)VDC=
		NPN open collector output	Load current: Max. 30mA, Residual voltage: Max. 0.4VDC=
		Voltage output	Load current: Max. 10mA, Residual voltage: Max. 0.4VDC=
	Response time (rise/fall)	Totem pole output	Max. 1μs (Cable length 2m, I sink = 20mA)
		NPN open collector output	
		Voltage output	
	Max. Response frequency	300kHz	180kHz
	Power supply	• 5VDC= ±5%(Ripple P-P: Max. 5%)	• 12-24VDC= ±5%(Ripple P-P: Max. 5%)
	Current consumption	Max. 80mA(disconnection of the load)	
Insulation resistance	Min. 100MΩ(at 500VDC megger between all terminals and case)		
Dielectric strength	750VAC 50/60Hz for 1 minute(Between all terminals and case)		
Mechanical specification	Connection	Radial connector type	Axial cable type, Axial cable connector type
	Starting torque	Max. 70gf·cm(0.007N·m)	Dependent on the coefficient of friction
	Moment of inertia	Max. 80g·cm ² (8×10 ⁻⁶ kg·m ²)	
	Shaft loading	Radial: 10kgf, Thrust: 2.5kgf	
Max. allowable revolution ^{※2}	5000rpm		
Vibration	1.5mm amplitude at frequency of 10 to 55Hz(for 1 min.) in each X, Y, Z direction for 2 hours		
Shock	Approx. Max. 75G		
Environment	Ambient temperature	-10 to 70°C, Storage: -25 to 85°C	
	Ambient humidity	35 to 85%RH, Storage: 35 to 90%RH	
Protection structure	IP50(IEC Standards)		
Cable	•ENA-□-□-□-□ ENC: Ø5mm, 4-wire, Length: 2m, Shield cable (AWG 24, Core wire diameter: 0.08mm, Number of cores: 40, Insulator out diameter: Ø1mm) •ENA-□-□-□-□ Ø5mm, 5-wire, Length: 2m, Shield cable (AWG 24, Core wire diameter: 0.08mm, Number of cores: 40, Insulator out diameter: Ø1mm)		
Accessory	Ø10mm coupling, Connector cable		
Approval	CE		
Unit weight	Approx. 345g	Approx. 494g	

※1 ' ' pulse is only for A, B phase. ※Environment resistance is rated at no freezing or condensation.
 ※2: Make sure that Max. response revolution should be lower than or equal to max. allowable revolution when selecting the resolution.
 [Max. response revolution(rpm)] = $\frac{\text{Max. response frequency}}{\text{Resolution}} \times 60 \text{ sec}$

■ Dimensions

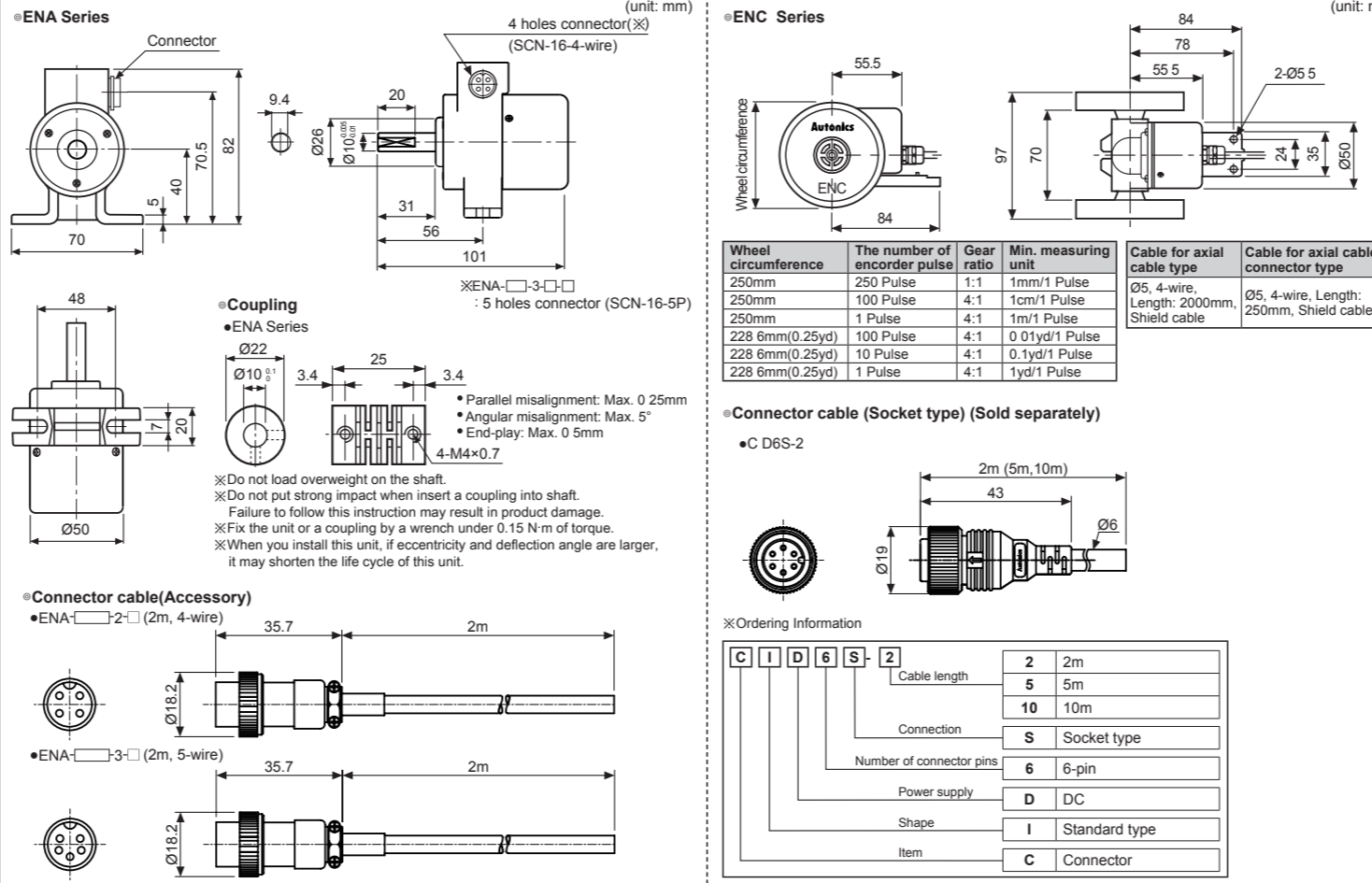

■ Connections

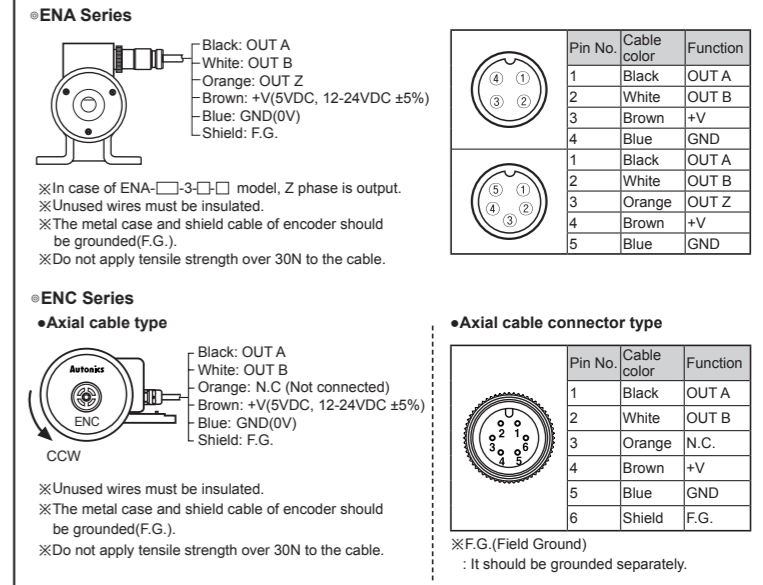

■ Output Waveforms

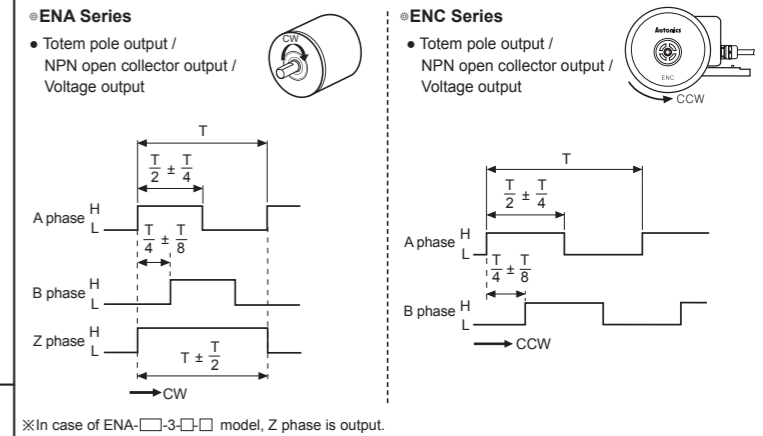

■ Caution during Use

- Follow instructions in 'Cautions during Use'. Otherwise, It may cause unexpected accidents.
- 5VDC, 12-24VDC power supply should be insulated and limited voltage/current or Class 2, SELV power supply device.
- For using the unit with the equipment which generates noise (switching regulator, inverter, servo motor, etc.), ground the shield wire to the F.G. terminal.
- Ground the shield wire to the F.G. terminal.
- When using switching mode power supply, frame ground (F.G.) terminal of power supply should be grounded.
- Wire as short as possible and keep away from high voltage lines or power lines, to prevent induc ive noise.
- Check the wire time and response frequency when extending wire because of distortion of waveform or residual voltage increment etc by line resistance or capacity between lines.
- This unit may be used in the following environments.
 - ①Indoors (in the environment condition rated in 'Specifications')
 - ②Altitude max. 2,000m
 - ③Pollution degree 2
 - ④Installation category II

■ Major Products

- Photoelectric Sensors
- Fiber Optic Sensors
- Door Sensors
- Door Side Sensors
- Area Sensors
- Proximity Sensors
- Pressure Sensors
- Rotary Encoders
- Connector/Sockets
- Switching Mode Power Supplies
- Control Switches/Lamps/Buzzers
- I/O Terminal Blocks & Cables
- Stepper Motors/Drivers/Motion Controllers
- Graphic/Logic Panels
- Field Network Devices
- Laser Marking System (Fiber, CO₂, Nd: YAG)
- Laser Welding/Cutting System
- Temperature Controllers
- Temperature/Humidity Transducers
- SSRs/Power Controllers
- Counters
- Timers
- Panel Meters
- Tachometer/Pulse (Rate) Meters
- Display Units
- Sensor Controllers